



XAPP058 (v4.1) March 6, 2009

Xilinx In-System Programming Using an Embedded Microcontroller

Contact: Randal Kuramoto

Summary

Xilinx® high-performance CPLD, FPGA, and configuration PROM families provide in-system programmability, reliable pin locking, and IEEE Std 1149.1 (JTAG) boundary-scan test capability. This powerful combination of features allows designers to make significant changes and yet keep the original device pinouts, thus, eliminating the need to re-tool PC boards. By using an embedded processor to program these CPLDs and FPGAs from an onboard RAM or EPROM, designers can easily upgrade, modify, and test designs, even in the field.

Xilinx Families

This application note can be used with the following Xilinx device families: Virtex® series, Spartan® series, CoolRunner® series, XC9500 series, Platform Flash PROM family, and XC18V00 family.

Introduction

The Xilinx CPLD and FPGA families combine superior performance with an advanced architecture to create new design opportunities that were previously impossible. The combination of in-system programmability, reliable pin locking, and JTAG test capability gives the following important benefits:

- Reduces device handling costs and time to market
- Saves the expense of laying out new PC boards
- Allows remote maintenance, modification, and testing
- Increases the life span and functionality of products
- Enables unique, customer-specific features

By using a simple JTAG interface, Xilinx devices are easily programmed and tested without using expensive hardware. Multiple devices can be daisy-chained, permitting a single four-wire Test Access Port (TAP) to control any number of Xilinx devices or other JTAG-compatible devices. The four mandatory signals comprising the JTAG TAP are:

- Test Clock (TCK)
- Test Mode Select (TMS)
- Test Data Input (TDI)
- Test Data Output (TDO)

The processor and JTAG chain schematic shown in [Figure 1, page 2](#) can help designers achieve these unprecedented benefits by providing a simple means for programming Xilinx CPLDs and FPGAs from design information stored in the embedded processor memory space. This design can be modified for remote downloading applications and the included reference C code can be compiled for the designer's processor of choice.

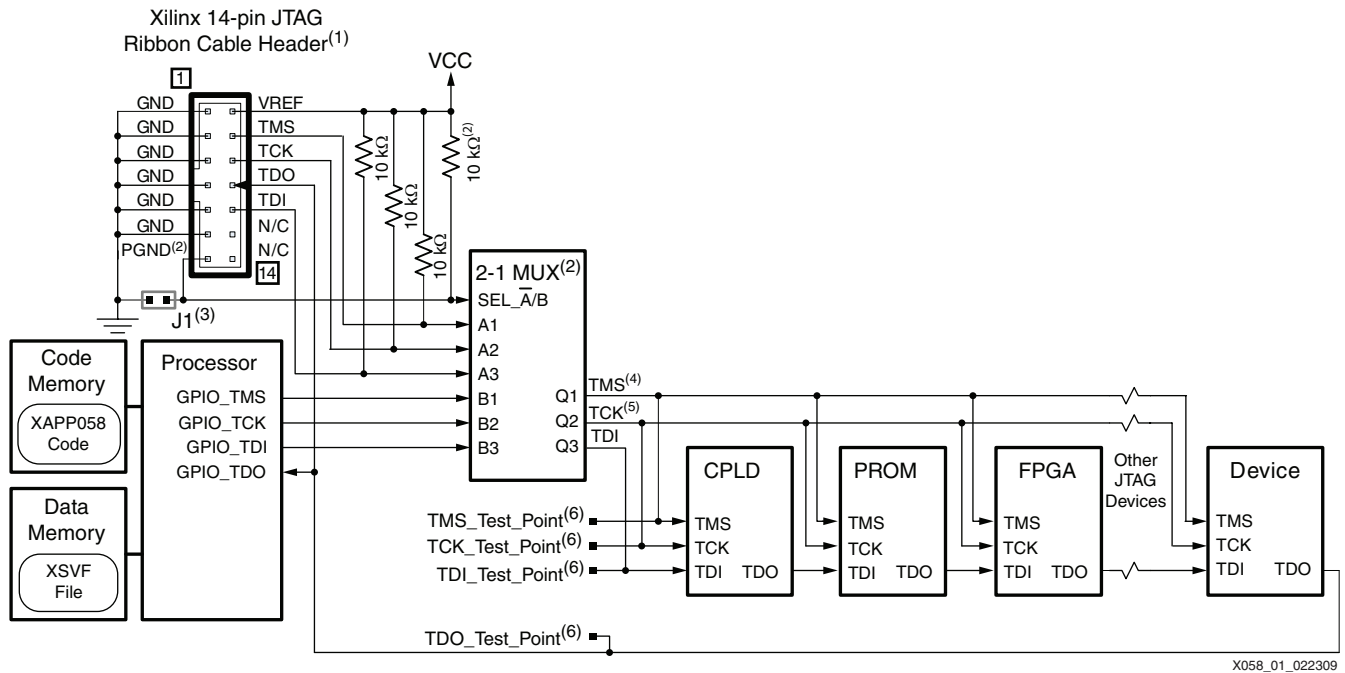

Figure 1: Microcontroller and JTAG Chain Schematic

Notes:

1. A JTAG cable header is required for prototype design downloading, production in-system programming, boundary-scan testing, and design/configuration debugging.
2. The 2-1 MUX is an example implementation from the *Platform Cable USB II* data sheet [Ref 1] that multiplexes control between the Xilinx JTAG cable and processor. The pull-up resistor on the MUX SEL_A/B signal selects the processor as the default controller. PGND drives Low to select the cable as the JTAG controller. See [Ref 1] for details regarding the pseudo-ground (PGND) pin on the 14-pin ribbon cable connector.
3. Jumper J1 is necessary to provide a method of switching the MUX to external JTAG controllers, JTAG connectors, or software that does not support the PGND function.
4. The TCK and TMS signals should be buffered and routed to minimize skew between TMS and TCK.
5. The integrity of the JTAG TCK signal is critical. Apply clock distribution and termination design practices to the TCK signal.
6. Test points on the JTAG signals enable oscilloscope or logic analyzer access for verification and debug of the in-system programming implementation.

To create device programming files, Xilinx provides iMPACT tool, included with the ISE® software. The iMPACT software reads standard JEDEC/BIT/MCS/EXO device programming files and converts them to a compact binary format XSVF format that can be stored in the onboard flash or RAM. The XSVF format contains both data and programming instructions for the CPLDs, FPGAs, and configuration PROMs. JEDEC files contain design information for CPLDs, BIT files for FPGAs, and MCS/EXO files for configuration PROMs. The processor reference code interprets the XSVF information and applies the corresponding JTAG signal sequence to program the Xilinx devices. Figure 2, page 3 shows the software flow from the design file to the XSVF programming file that is interpreted in the embedded system to program the Xilinx devices.

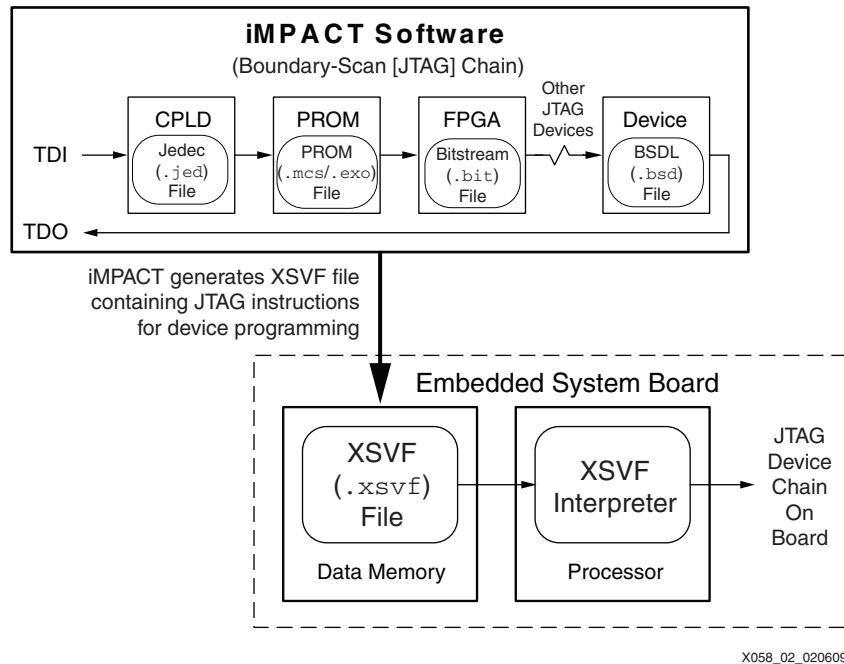

Figure 2: XSVF File Generation Flow to Embedded System

The files and utilities associated with this application note are available in a package for downloading from:

<https://secure.xilinx.com/webreg/clickthrough.do?cid=113970>

Programming Xilinx CPLDs, FPGAs, and Configuration PROMs

Serial Vector Format (SVF) is a syntax specification for describing high-level IEEE Std 1149.1 (JTAG) bus operations. SVF was developed by Texas Instruments and has been adopted as a standard for data interchange by JTAG test equipment and software manufacturers such as Teradyne, Tektronix, and others. Xilinx CPLDs, FPGAs, and configuration PROMs accept programming and JTAG boundary-scan test instructions in SVF format, via the JTAG test access port (TAP). The timing for these TAP signals is shown in [Figure 8, page 12](#). Since the SVF format is ASCII and has larger memory requirements, it is inefficient for embedded applications. Therefore, to minimize the memory requirements, SVF is converted into a more compact (binary) format called XSVF.

Note: For a description of the SVF and XSVF commands and file formats, see [\[Ref 2\]](#).

The iMPACT software tool, included with ISE software, can output the device programming commands and data to an SVF file or to a compact XSVF file. The XSVF file is appropriate for use with the reference C code. The SVF is useful as a human-readable reference of the underlying XSVF contents. In this design, the reference C code interprets the XSVF file and provides the required JTAG TAP stimulus to the target, performing the programming and (optional) test operations originally specified in the XSVF file. The combination of iMPACT software, the XSVF file format encapsulating the programming instructions and design data, and reference C code, enables a simple software flow for programming Xilinx devices in system from an embedded processor.

The flow for creating the programming files that are used with this design are shown in [Figure 3, page 4](#), [Figure 4, page 4](#), and [Figure 5, page 5](#).

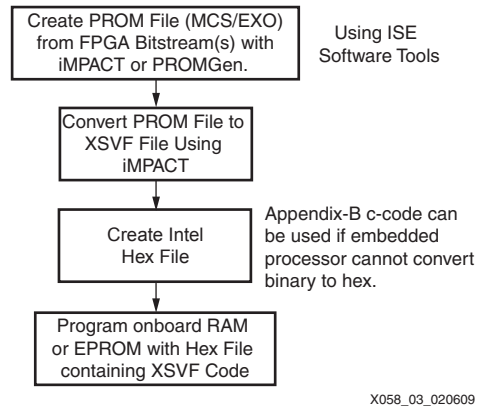

Figure 3: Configuration PROM Programming File Creation and Storage Flow

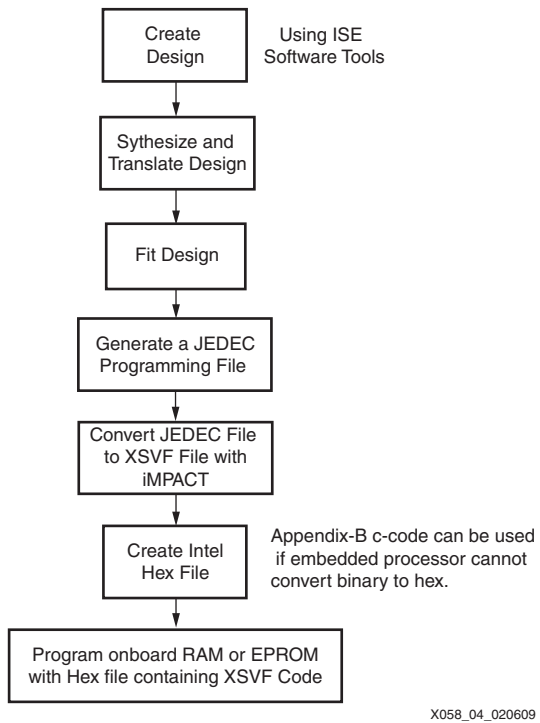

Figure 4: CPLD Programming File Creation and Storage Flow

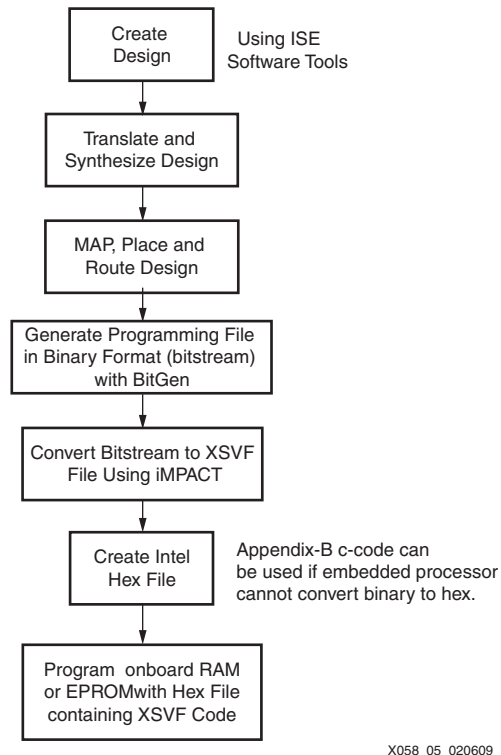

Figure 5: FPGA Programming File Creation and Storage Flow

Creating an XSVF File Using iMPACT Software

This procedure describes how to create an XSVF file from a FPGA, CPLD, or PROM programming file. This flow assumes that the ISE software is being used. This software package includes the Xilinx CPLD and FPGA implementation tools and the iMPACT programming and file generation software.

iMPACT is supplied with both a graphical and batch user interface. The graphical tool can be launched from the Project Manager. The batch tool is available by opening a shell and invoking **impact -batch** on the command line.

Using iMPACT Batch Tool to Create XSVF Files

After generating the programming files as specified in [Figure 3, page 4](#), [Figure 4, page 4](#), and [Figure 5, page 5](#), the user can use the iMPACT batch tool to generate XSVF files:

1. Invoke the iMPACT batch tool from the command line in a new shell:

```
impact -batch
```

The following messages appear:

```
Release <Release Number> - iMPACT <Version Number>
Copyright (c) 1995-2009 Xilinx, Inc. All rights reserved.
```

2. Put iMPACT into boundary-scan mode using the following command:

```
setMode -bs
```

3. Define the ordered set of devices in the JTAG chain. For each device, add the device to the JTAG chain using the following command:

```
addDevice -p # -file "filename.xxx"
```

where the # determines the position in the JTAG chain and `filename.xxx` is the full path to the file that represents the device being added. Position 1 is the device closest to the

initial JTAG TDI input. For a device with a design that needs to be programmed, `filename.xxx` is the device design file. The file extension for a CPLD design file is `.jed`. The file extension for a FPGA design file is `.bit`. The extension for a PROM file is `.mcs` or `.exo`.

PROMs require a special attribute on the `addDevice` command line that specifies the PROM type. To add a PROM device to the JTAG chain, use the following command:

```
addDevice -p # -sprom promtype -file "filename.xxx"
```

where the `#` determines the position in the JTAG chain and **promtype** is `xcf32p`, `xcf16p`, `xcf08p`, `xcf04s`, `xcf02s`, `xcf01s`, `xc18v04`, `xc18v02`, `xc18v01`, or `xc18v512`. The file attribute, `filename.xxx`, is the full path to the PROM data file with a `.mcs` or `.exo` extension.

For devices not being programmed (e.g., devices from vendors other than Xilinx), add the BSDL file corresponding to the device. A BSDL file typically has the file extension `.bsd`. BSDL files are available from the device manufacturer. Xilinx BSDL files are available from the [download area](#) of the Xilinx website. A device can be added using its BSDL file as follows:

```
addDevice -p # -file "filename.bsd"
```

where the `#` determines the position in the JTAG chain and `filename.bsd` is the full path to the device's BSDL file.

Additional details regarding the `addDevice` command can be found in the [iMPACT online manual](#).

4. After defining the complete JTAG chain, direct the iMPACT output to an XSVF file using the following command:

```
setCable -port xsvf -file "filename.xsvf"
```

where `filename.xsvf` is the full path to the output XSVF file.

5. Specify an iMPACT operation on a specific device. iMPACT writes the operation instructions and data to the XSVF file. The most common operations are listed in [Table 1](#). For a detailed list of all operations, see the iMPACT online manual.
6. After specifying an iMPACT operation, close the XSVF file using the following command:

```
closeCable
```
7. Quit the iMPACT batch mode using the following command:

```
quit
```

Table 1: Selected iMPACT Batch Command

Command	Description and Usage
erase -p -position <position>	
	Generates an XSVF file to describe the boundary-scan sequence to erase the specified part. The -p is used to specify the position of the device in the JTAG chain being targeted.
verify -p -position <position>	
	Generates an XSVF file to describe the boundary-scan sequence to read back the device contents and compare it against the contents of the original design file. The -p flag indicates the position in the JTAG chain of the device to be verified.
program [-e -erase] [-v -verify] -p -position <position> [-u -usercode <codestring>] [-parallel] [-loadfpga]	
	<p>Generates an XSVF file to describe the boundary-scan sequence to program the device using that programming data specified JEDEC/BIT/MCS/EXO file. The -p flag refers to the JTAG chain device position. The -u refers to the usercode being specified. The -parallel flag indicates the PROM parallel configuration bit is set to load the FPGA in SelectMAP mode. The -loadfpga has the Xilinx PROM configure the FPGA automatically after being programmed.</p> <p>Recommended command for programming a CPLD or configuration PROM:</p> <pre>program -e -v -p 1</pre> <p>Recommended command for programming an FPGA:</p> <pre>program -p 1</pre>
readidcode -p -position <position>	
	Generates an XSVF file that verifies the expected 32-bit IDCODE from the device at <position> in the boundary-scan chain.

Using the iMPACT GUI to Create XSVF Files

After generating the programming files as specified in [Figure 3, page 4](#), [Figure 4, page 4](#), and [Figure 5, page 5](#), the user can use the iMPACT GUI to generate XSVF files

1. Invoke the iMPACT icon in the ISE Accessories start menu to start iMPACT and create a new project. In the iMPACT wizard select **Prepare a Boundary-Scan File**, and then select **XSVF** from the pull-down menu as shown in [Figure 6](#) and then click **Finish**.

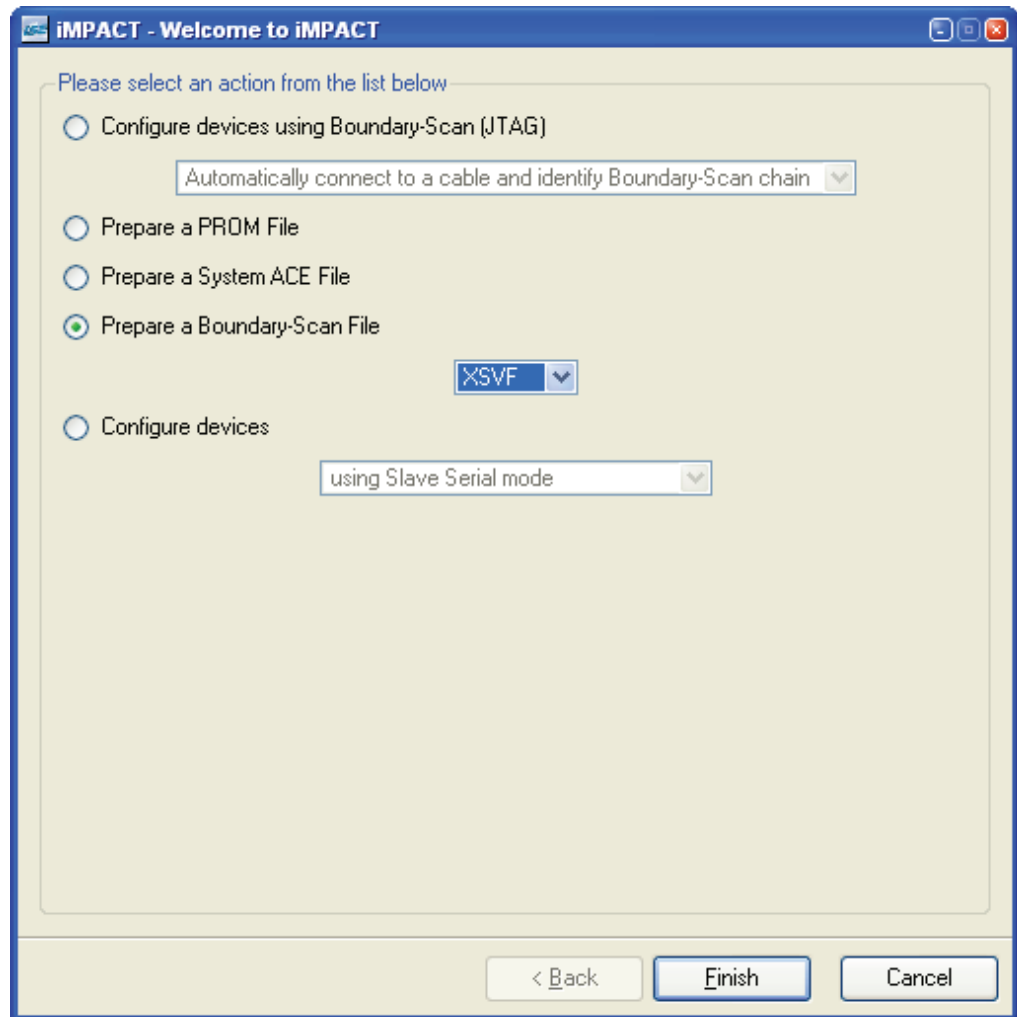

X058_06_020209

Figure 6: iMPACT Wizard

2. In the Create a New XSVF File dialog, specify an output XSVF file name and click the **Save** button to save the output from the following steps within the named XSVF file. Click **OK** when the File Generation Mode prompt appears.
3. iMPACT asks for the file of the first device that is closest to the initial JTAG TDI input in the boundary-scan chain. When adding a device that needs to be programmed to the JTAG chain, specify the device design file. The file extension for a CPLD design file is `.jed`. The file extension for a FPGA design file is `.bit`. The extension for a PROM file is `.mcs` or `.exo`. For PROM files, also specify the PROM type when prompted by iMPACT. For third-party devices, or for Xilinx devices not being programmed, use the Add Non-Xilinx Device menu item. This prompts the designer for a BSDL file corresponding to the device. A BSDL file typically has the file extension `.bsd`. BSDL files are available from the device manufacturer. Xilinx BSDL files are available from the [download area](#) of the Xilinx website.

If no BSDL file is available, iMPACT can create a BSDL file given the device's JTAG instruction register length in bits.

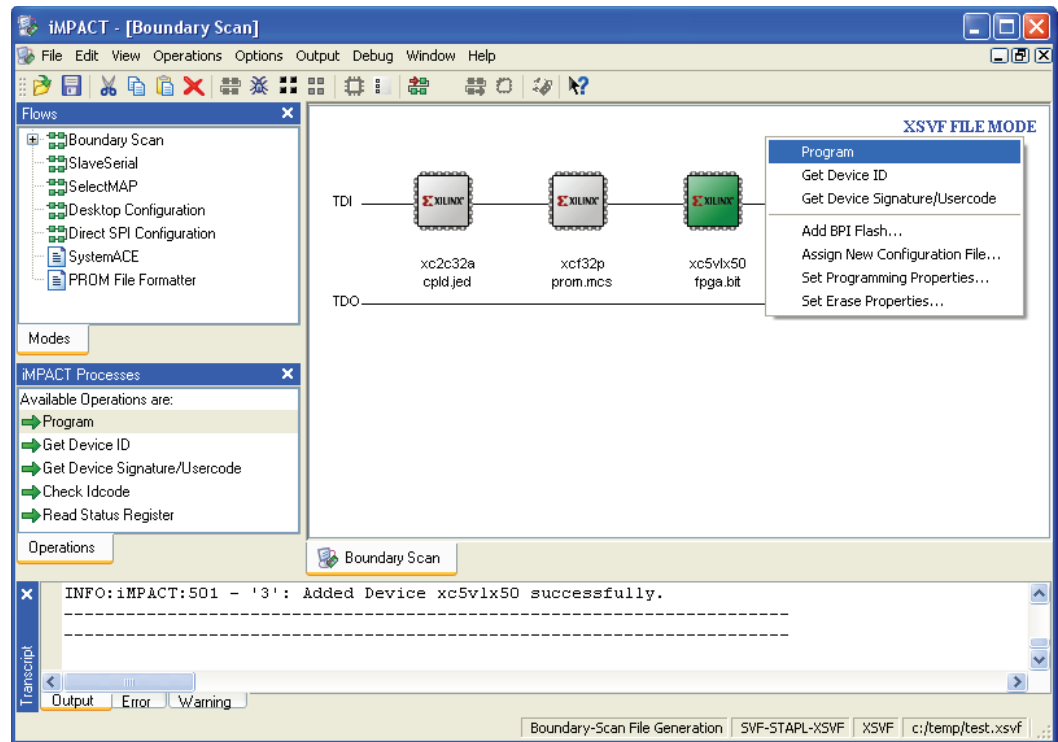

X058_07_021709

Figure 7: Add Device

4. If there is more than one device in the chain, then add each device to the chain via the following procedure. To add a device at the end of the chain, right-click in the iMPACT window to the right of the last device in the chain. iMPACT presents a menu of items for adding a device to the chain. For Xilinx devices, choose the **Add Xilinx Device** menu item, and specify the `.bit`, `.jed`, `.mcs`, or `.bsd` file corresponding to the Xilinx device. For other devices, choose the **Add Non-Xilinx Device** menu item, and specify the device's BSDL file or create a BSDL for the device. Repeat this step until all devices are specified in the chain.
5. After the complete boundary-scan chain is specified, select the target device (it should be highlighted) and right-click to see the available operations for the device. Select the operation(s) to be written to the XSVF file in the order needed (Figure 7). The recommended operation and operation attributes follow for specific device types:
 - ◆ CPLDs and PROMs: Operation-->Program with the **Erase before Programming** and **Verify** attributes selected.
 - ◆ FPGAs: Operation-->Program (The **Erase Before Programming** and **Verify** attributes of the program operation are not supported for FPGA devices.)
6. **Output** → **XSVF File** → **Stop writing to the XSVF File** to exit and stop writing to the XSVF file.

Storing the XSVF File in an EPROM

To store the XSVF file in an EPROM, the binary XSVF file must be converted to an Intel Hex or similar PROM format file. Most embedded processor development system software automatically converts included binary files to the appropriate format. For systems without this capability, reference C code to perform this conversion can be found in [“Appendix B: Binary to Intel Hex Translator,”](#) page 20.

Software Limitations

iMPACT can generate XSVF files only for Xilinx programmable logic devices and Xilinx JTAG in-system programmable PROMs. Designers should verify that the development software can create an XSVF file for the specific device to be programmed.

Hardware Design

As shown in [Figure 1, page 2](#), the reference design requires:

- A microprocessor
- Enough memory to contain both the compiled C-code and the XSVF file
- Three processor-controlled outputs for the JTAG TCK, TMS, and TDI signals
- One processor-readable input for the JTAG TDO signal

Hardware Design for the JTAG Chain

Interfacing the processor to the board-level JTAG signals is typically done in one of two ways. In some implementations, the JTAG signals are connected to general-purpose I/O (GPIO) pins on the processor. [Figure 1, page 2](#) shows an example of this type of implementation. In other implementations, memory-mapped registers are used to drive or capture the JTAG signals. Both solutions are equally effective. Either way, four I/O pins are required: three output pins to drive the JTAG TCK, TMS, and TDI signals, and one input pin to read the JTAG TDO signal.

The JTAG bus is a multipurpose bus. It is often used for board-level boundary-scan test, cable-based downloading of prototype designs for programmable logic devices, and as an access point for debugging programmable logic or processors. For this reference design, the processor uses the JTAG bus to program programmable logic devices or JTAG in-system programmable PROMs.

Because of the multipurpose nature of the JTAG bus, a hardware implementation that enables different JTAG masters to control the JTAG chain is essential. A hardware solution must allow for the appropriate JTAG master to control the JTAG chain when needed, and must avoid signal contention on the JTAG bus from multiple JTAG masters. Several different kinds of implementations can satisfy these requirements.

The example JTAG chain schematic in [Figure 1, page 2](#) includes a multiplexer that enables switching between the processor and an external JTAG cable, which can also act as master of the JTAG bus (by default, the processor has control). This example is derived from the multiplexer example in [\[Ref 1\]](#). The implementation takes advantage of the Xilinx Platform Cable USB II PGND function to automatically switch control to the cable during iMPACT software operations. PGND is driven Low during iMPACT software operations. See [\[Ref 1\]](#) for details regarding the PGND function and software that supports the PGND function. The multiplexer example in [Figure 1, page 2](#) is enhanced with a critical jumper (J1) that enables external JTAG masters to control the bus when the external JTAG hardware or software does not support a PGND-like function.

The JTAG chain can span long distances and connect many devices on a board. Special attention to the design and layout of the JTAG TCK signal are required to ensure good signal integrity at the TCK pin of all devices in the JTAG chain. The use of board-level clock design and routing guidelines that require proper buffering, termination, and layout, are essential. Because the TMS signal is also routed to all devices in the JTAG chain, the TMS signal must be designed and routed such that skew is minimized between TMS and TCK.

Multiple devices with different I/O voltage requirements can be connected to the JTAG chain. For devices with configurable JTAG I/O voltage support, choose an I/O voltage level that is compatible with the rest of the JTAG chain. Some devices can require the insertion of level translators between the device's JTAG TAP pins and the rest of the JTAG chain to ensure compatible signal levels.

Refer to [\[Ref 3\]](#) for additional JTAG hardware design recommendations.

Memory Requirements

Typical implementations of the reference design require a processor with significant memory resources for code storage, run-time memory, and XSVF file storage.

The memory requirement for code storage depends on the processor instruction set and compiler. A reasonable code size estimate can be obtained by compiling the reference C code for a select processor. As a rough reference, the `xapp058_example.exe` can be compiled to a 17 KB file without run-time libraries.

The run-time memory requirement is dominated by temporary buffers for storing the bit values for one JTAG shift operation. By default, the temporary buffers are defined in a data structure that is stored on the stack—the default size for the data structure is approximately 50 KB. Optimizations to the reference C code can be made to either store the temporary buffers in a location other than the stack or to shorten the length of the temporary buffers. The lengths of the temporary buffers are defined by the `MAX_LEN` attribute. See the `readme.txt` in the reference design package and the `lenval.h` file for information about the temporary buffers.

Memory is also required to store the XSVF file. Typically, the entire XSVF file is stored within the local memory space of the embedded processor. The XSVF file depends on the target device type, on the architecture of the JTAG chain, and on the selected operations for the target device. To obtain an accurate XSVF file size estimate, a sample design must be created for the target device within the target JTAG chain, and the corresponding XSVF file must be created using the desired iMPACT operations.

[Table 2](#) lists sample iMPACT 10.1.03 XSVF file sizes for typical programming operations on representative Xilinx devices (in single-device JTAG chains). For sample CPLDs, the Erase Before Programming and Verify options are used when generating the XSVF using the desired iMPACT operations. For sample PROMs, the XSVF file is generated from a full-sized MCS file that matches the PROM size using the iMPACT Program operation, including the Erase Before Programming and Verify options. For sample FPGAs, the XSVF file is generated from an uncompressed bitstream using the iMPACT Program operation without options.

Some techniques can be used to reduce XSVF file storage requirements. File compression techniques can be used to compress a stored XSVF file (see [\[Ref 4\]](#)).

Alternatively, the reference C code can be modified to wait for pieces of the XSVF that are transferred as smaller blocks to the embedded system for remote update applications.

Table 2: Sample XSVF File Sizes

Device Type	File Size (Bytes)
XC9536	45,624
XC95288	726,170
XC9536XL	39,453
XC95288XL	136,305
XC2C32A	11,442
XC2C512	210,791
XCF04S	3,222,351
XCF32P	23,630,691
XC3S700A	344,468
XC5VLX50	1,582,011

Firmware Design

This reference design is provided with C code that can be ported and compiled to an embedded processor. The main function of the C code is to interpret a given XSVF file and to drive the JTAG bus with corresponding signal sequences. See [Ref 2] for details of the commands in the XSVF file.

TAP Timing

Figure 8 shows the timing relationships of the TAP signals. Table 3, page 13 provides example TAP timing parameters for the XC9500 CPLD. See the data sheet for each device in the JTAG chain to determine the JTAG TAP timing parameters for each device.

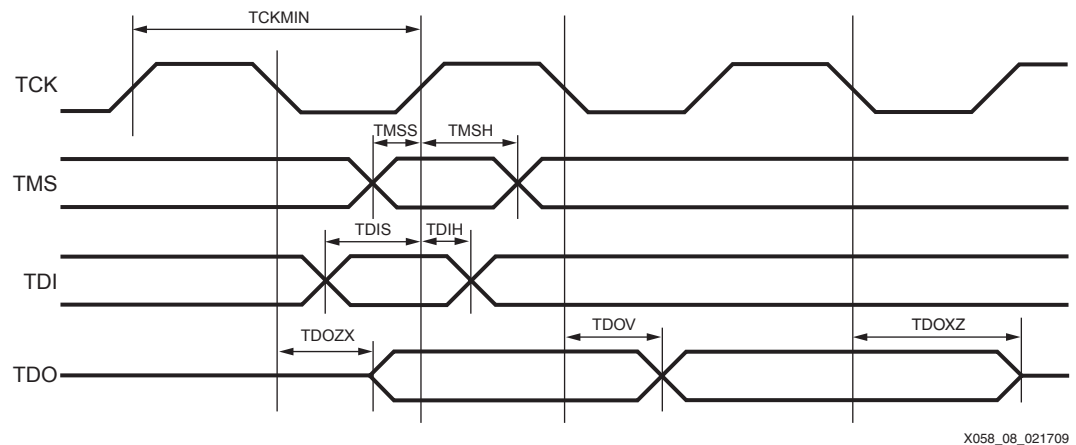

Figure 8: Test Access Port Timing

Key JTAG TAP timing considerations include:

- A JTAG device requires a minimum TCK period (TCKMIN).
- A JTAG device samples TMS and TDI on the rising edge of TCK. The device requires TMS and TDI to be valid for a minimum setup time (TMSS/TDIS) before the rising edge of TCK and for a minimum hold time (TMSH/TDIH) after the rising edge of TCK.
- A JTAG device outputs a new TDO value by a maximum time (TDOV) after the falling edge of TCK.

See the data sheets of the devices in the JTAG chain for these timing parameters.

The reference C code controls the primary JTAG TAP signals. The speed at which the code toggles the JTAG TAP signals is dependent on the processor speed. Often, the toggle rate from the processor is sufficiently slow and the device timing is sufficiently fast that no timing violations occur. To ensure proper TAP timing in the reference C code implementation, the designer should:

- Check the data sheet of each device in the JTAG chain for the TCKMIN period.

The longest TCKMIN period of all devices in the JTAG chain is the minimum TCK period for the entire chain. Check that the minimum TCK period driven from the reference C code implementation in the processor is greater than or equal to the minimum TCK period for the entire chain (in other words, the TCK can not run faster than the slowest device in the chain).
- Check the data sheet for each device in the JTAG chain for minimum TMS setup time.

The longest TMS setup time is the minimum TMS setup time for the entire JTAG chain. Check that the minimum time from a TMS transition to the next rising edge of TCK is greater than or equal to the minimum TMS setup time for the entire chain. Similarly, check the minimum TMS hold time, which is the time from the rising-edge of TCK to the transition of TMS to a new value.

- Check the TDI setup and hold times for each device in the chain.

The timing checks for TDI and TDO are different than the timing checks for TCK and TMS because TDI and TDO are daisy-chained from one device to the next in the JTAG chain. The processor-driven TDI must meet the TDI setup and hold time for the first device in the JTAG chain. The TDO output from the first device must meet the TDI setup and hold for the second device in the JTAG chain, and so on. Finally, the TDO output from the last device in the JTAG chain should not be sampled before the maximum TDOV time (maximum time from the falling edge of TCK to when TDO output data is valid).

If the JTAG TAP timing is violated, additional delays must be added in the reference code. To delay signal transitions or TCK toggle rates, add a delay in the setPort function within the PORTS.C file. To delay the sample timing of TDO, add a delay in the readTDOBit function within the PORTS.C file.

Note: Some compilers remove empty loops. Delay loops must be implemented such that they are retained during code compilation.

Table 3 lists the XC9500 timing parameters for the TAP waveforms shown in Figure 8, page 12. For other device families, see the device family data sheet for TAP timing characteristics.

Table 3: XC9500 Test Access Port Timing Parameters (ns)

Symbol	Parameter	Min	Max
TCKMIN	TCK Minimum Clock Period	100	
TMSS	TMS Setup Time	10	
TMSH	TMS Hold Time	10	
TDIS	TDI Setup Time	15	
TDIH	TDI Hold Time	25	
TDOZX	TDO Float-to-Valid Delay		35
TDOXZ	TDI Valid-to-Float Delay		35
TDOV	TDO Valid Delay		35

Special Cases for the XSVF File and XSVF Interpreter

As mentioned previously, XSVF is a compact, binary version of the de facto standard SVF file format. The SVF file contains deterministic JTAG commands and data. For most cases, the XSVF is a near identical reflection of a corresponding SVF file—though in a more compact form. However, for two special cases, the XSVF is created with a slight modification or optimization from a corresponding SVF file.

Exception Handling for XC9500/XL/XV Programming

Figure 9 shows the state diagram for the internal device programming state machine, as defined by the IEEE Std 1149.1.

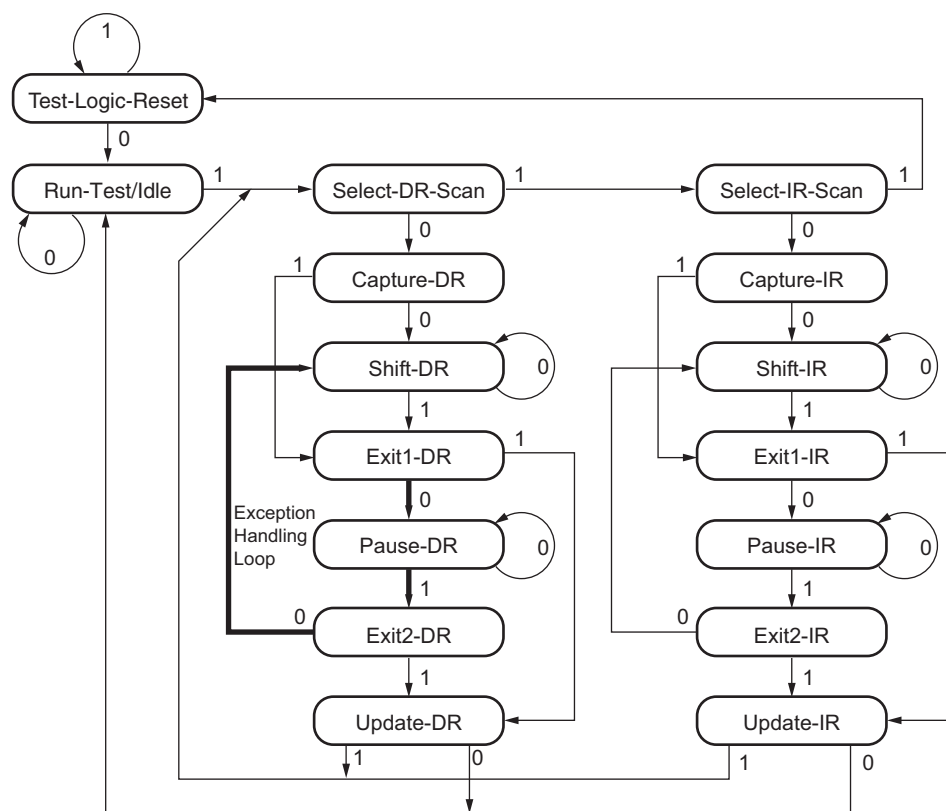

Note: The values shown adjacent to each transition represent the signal present at TMS during the rising edge of TCK.

X058_09_013009

Figure 9: TAP State Machine Flow

The C code drives the IEEE Std 1149.1 TAP controller through the state sequences to load data and instructions and capture results. The XC9500/XL/XV CPLD can require a special TAP state sequence for exceptional erase and program conditions. The XSVF reference code detects the exceptional condition and applies the following special TAP sequence:

EXIT1-DR, PAUSE-DR, EXIT2-DR, SHIFT-DR, EXIT1-DR, UPDATE-DR, RUN-TEST/IDLE

The special TAP state sequence is applied in response to a CPLD that requires additional time for optimal erase or program results. The special sequence can be applied multiple times. Upon entering the Run-Test/Idle state at the end of the special sequence, the C code provides additional time for the CPLD's erase or program operation. The C code increments the amount of time by 25% on each repeat of the special sequence.

This “exception handling loop” is attempted no more than N times, where N is defined within the XSVF file. The iMPACT software sets N to 16 in XSVF files for XC9500/XL/XV CPLDs and to zero in XSVF files for all other devices. If the TDO value does not match after N attempts, the C code issues an error message.

See [Ref 5] for further details regarding the special exception handling for the XC9500/XL/XV CPLD programming algorithm.

XSVF Files for FPGA Configuration

The FPGA configuration algorithm contains a JTAG data shift command that shifts the entire FPGA configuration bitstream into the JTAG bus (see [Ref 6] for one example of an FPGA JTAG configuration algorithm). Because the FPGA bitstream is millions of bits in length, the corresponding JTAG shift command specifies a shift length that is millions of bits long (an example can be found in an SVF file for configuring an FPGA). To optimize the shift information

for an embedded processor, an XSVF file is generated with the long bitstream shift represented as multiple XSVF commands—each command defines a short segment of the original bitstream. This effectively reduces the run-time buffer requirements in the embedded code. See the `readme.txt` in the reference design package for corresponding buffer length requirements in the reference C code.

Firmware Implementation

This section outlines the basic steps to implementing the hardware and reference C code in an embedded processor.

Step 1: Define the JTAG Chain and Programming Tasks

First, identify the set of devices in the JTAG chain. Then, identify target device(s) within the JTAG chain that the embedded processor will program. For devices not programmed by the embedded processor, obtain the BSDL files from the device manufacturer.

Step 2: Determine XSVF File Size

After the target devices to be programmed are identified, the XSVF file size can be determined. For each of the target devices to be programmed, obtain a sample design file. Then, follow the iMPACT software instructions for generating an XSVF file that performs the desired operations on the target devices.

Step 3: Determine XSVF File Location

After determining the XSVF file size, determine the location where the XSVF file is stored. The XSVF can be statically stored in non-volatile memory when the embedded processor is the primary configuration source for the Xilinx device. Alternatively, the XSVF can be dynamically transferred to a RAM location in the embedded system for remote update applications. The storage location of the XSVF file determines the method the XSVF interpreter (reference C code) uses to retrieve the XSVF file data.

Step 4: Planning Processor Resources

Sufficient processor memory resources must be available to store code, store the XSVF file, and run code. The XSVF file and its storage location defines one memory requirement for the embedded system. In addition, the reference code size determines another set of memory requirements for code storage and code execution memory. Finally, the run-time memory requirements must also be considered.

The reference code size depends on the processor instruction set and compiler. Compiling the reference code with the preferred compiler for the embedded processor provides an estimate for the code size.

Run-time requirements are primarily determined by the size of the `SXsvfInfo` data structure defined in the `micro.c` file. One instance of the `SXsvfInfo` data structure is created at run time on the stack (the stack location of the `SXsvfInfo` data structure instance can be changed through modifications in the `micro.c` code). The size of the `SXsvfInfo` data structure is dominated by the instances of the `lenVal` data structures within the `SXsvfInfo` data structure. There are up to seven instances of the `lenVal` data structure within the `SXsvfInfo` data structure. The `lenVal` defines buffers for bit values used in the JTAG shift operations. The size of the `lenVal` buffers are defined by the `MAX_LEN` parameter in the `lenval.h` file. By default, the `MAX_LEN` is 7,000 bytes. If possible, do not change the default `MAX_LEN` value; this default value allows margin for large JTAG shift operations in future devices. If required, the `MAX_LEN` parameter can be reduced to optimize the `SXsvfInfo` data structure size. See the `readme.txt` and `lenval.h` files for guidelines on reducing the `MAX_LEN` value.

A legacy feature of the XSVF are special XSVF compression commands that optimized the XSVF for programming XC9500/XL/XV CPLDs. These XSVF compression commands are not supported in the XSVF output from the iMPACT software. If the implementation is not required to support legacy XSVF files that contain special XSVF compression commands, then remove

the `#define` for `XSVF_SUPPORT_COMPRESSION` in `micro.c`. Removal of the `#define` for the `XSVF_SUPPORT_COMPRESSION` can reduce the `SXsvfInfo` data structure size by over 40% and can reduce the code size by a modest amount.

Step 5: Design Processor I/O

Determine the hardware method that the processor uses to control and read the JTAG bus signals. Typical implementations use processor GPIO or memory-mapped registers. See descriptions of example implementations in the “[Hardware Design for the JTAG Chain](#)” section.

Step 6: Design JTAG Bus Control Scheme

Because the JTAG bus is typically shared between the embedded processor and external JTAG controllers, such as the Xilinx iMPACT software and Xilinx cables, a JTAG bus multiplexing scheme is advised. See [Figure 1, page 2](#) for an example JTAG bus multiplexing scheme that provides selectable control of the JTAG bus from either the embedded processor or external JTAG hardware and software.

Add test points on the JTAG bus for verification and debug access.

Step 7: Porting Reference C Code

The key functions, whose implementations are required to be ported to the embedded processor, are located in the `ports.c` file. The functions include:

- ◆ `setPort`: sets a JTAG output signal (TCK, TMS, or TDI) to a specified value. The `setPort` implementation depends on the design of the processor I/O for the output JTAG signals.
- ◆ `readTDOBit`: reads (i.e., samples) the JTAG input signal (TDO) value. The implementation of the `readTDOBit` function must return the JTAG input signal value. The implementation depends on the design of the processor I/O.
- ◆ `readByte`: returns the next byte from the XSVF file. The `micro.c` code calls the `readByte` function in order to read successive bytes from the XSVF file. The implementation of the `readByte` function must also remember the last read position of the XSVF file. The implementation depends on the location of the XSVF file. For example, when the XSVF file is stored in memory, the `readByte` implementation typically uses a pointer that returns the next byte from an array location in memory.
- ◆ `waitTime`: consumes (i.e., waits) for at least the specified number of microseconds (waiting for longer is okay), specified by an integer parameter value. The minimum waiting time is required to allow devices to complete certain operations, such as a PROM erase operation. The implementation must satisfy two requirements:
 - The `waitTime` function must interpret the integer parameter value as a time in microseconds.
 - The `waitTime` function must also interpret the integer parameter value as a number of TCK pulses that must be applied during the waiting time (pulsing TCK for a number of times that is greater than the number specified in the integer parameter is okay). The minimum TCK pulses are used to clock certain device operations, such as the FPGA startup sequence.

See the `waitTime` function in the `ports.c` file for example implementations that satisfy the requirements.

Verifying and Tuning the Design Implementation

This section outlines the basic steps for verifying the correctness of the reference design implementation.

Step 1: Verify JTAG Chain

Connect the Xilinx cable to the JTAG chain, and use the iMPACT software to apply desired boundary-scan operations to target devices in the JTAG chain. The iMPACT software

operations should match those operations that are to be performed by the embedded processor.

In the case of an iMPACT software failure, check the following:

- Check that the Xilinx cable is the selected master controller for the JTAG chain (i.e., check for correct JTAG bus multiplexer configuration).
- Check that the JTAG chain is defined correctly in the iMPACT boundary-scan window.
- Check the TCK signal integrity. The TCK edges should rise or fall monotonically without glitches at the TCK pin of each device.

Step 2: Verify XSVF Files

While iMPACT is connected to the JTAG chain via a Xilinx cable, follow the instructions given in the “[Creating an XSVF File Using iMPACT Software](#)” section. Generate a minimal XSVF that performs only the Get Device ID operation on one target device in the JTAG chain. This device ID XSVF file can be used to validate basic functionality of the reference code implementation. Also, generate the XSVF file that performs the desired programming operation on the target device in the JTAG chain.

After generating the XSVF files, use iMPACT to validate them on the JTAG chain using the following procedure.

1. Restart iMPACT and create a new project for boundary-scan configuration.
2. Add one of the XSVF files to the boundary-scan window.
3. Select the **XSVF** file icon in the boundary-scan window.
4. Right-click on the **XSVF** file icon and invoke the **Execute SVF/XSVF** menu item to execute the XSVF file through the Xilinx cable to the JTAG chain.
5. Verify that the XSVF file execution is successful. To verify each XSVF file, repeat this procedure for each XSVF file.

In the case of an iMPACT software XSVF execution failure, check the following:

- Check that the Xilinx cable is the selected master controller for the JTAG chain (i.e., check for correct JTAG bus multiplexer configuration).
- Check that the JTAG chain is defined correctly in the iMPACT boundary-scan window.

Step 3: PORTS.C waitTime Calibration

Calibrating the implementation of the waitTime function within the `ports.c` file is critical for success of XSVF file operations in the embedded system. The reference design package includes files for calibrating the waitTime function implementation. See the `readme_ports_c_waittime_calibration.txt` file in the reference design package for details about the calibration method and associated files.

Here are some general guidelines for calibrating the waitTime function (these also apply to the instructions in the “[Step 4: JTAG TAP Timing Verification](#)” section):

- Use an oscilloscope to probe the JTAG bus. The oscilloscope provides a visual of the calibration results.
- Run the calibration files using non-debug code to ensure that the calibrated timing measurements are accurate for the production version of the embedded system.
- Check the shorter calibration timing tests to ensure proper timing for shorter wait times.
- Check the longer calibration timing tests to ensure timing calculations or loops in the waitTime function implementation do not overflow and result in unexpectedly short wait times.

If the calibration tests show that the waitTime function does not meet the requirements, then try or check the following:

- To increase the resulting wait time, increase the multiplication factor for the number of TCK pulses to be applied.
- If delay loops are used, check that the compiler is not removing empty loops.

Step 4: JTAG TAP Timing Verification

Using one of the waitTime calibration XSVF files (or the Get Device ID XSVF file that was generated in “[Step 2: Verify XSVF Files,](#)” page 17), and with the oscilloscope probes on the JTAG signals, execute the XSVF file and check the timing of the JTAG signal transitions. The basic JTAG TAP signal timing requirements are outlined in the TAP Timing section.

Tips for checking the JTAG TAP signal timing:

- Use a waitTime calibration XSVF for checking the TCK period as TCK toggles during the wait time.
- Use a waitTime calibration XSVF for checking the timing of a TMS edge to the following TCK rising edge.
- Use the Get Device ID XSVF for checking the timing of a TDI edge to the following TCK rising edge.
- If the JTAG TAP timing verification results in timing violations, then try the following:
 - ◆ For TCK periods or setup times that are too short, insert a delay at the beginning of the setPort function.
 - ◆ For a readTDOBit function that reads before TDO is valid, insert a delay at the beginning of the readTDOBit function.

Note: Some compilers remove empty loops. When inserting delays, ensure an implementation that is not removed by a compiler optimization.

Step 5: Basic JTAG Chain Test with the Embedded Processor

Start testing the embedded implementation of the reference code using a small XSVF file. The Get Device ID XSVF, created in “[Step 2: Verify XSVF Files,](#)” page 17, is a small XSVF file from iMPACT that tests for a valid device ID return value. Prepare the embedded system with the Get Device ID XSVF file. Then execute the Get Device ID XSVF file to test the operation of the embedded reference code implementation.

If the Get Device ID XSVF fails, try the following checks:

- Check that the XSVF file works when run via iMPACT through a Xilinx cable to the JTAG chain.
- Check for TCK signal integrity.
- Check the return value from TDO. If the return value pattern does not match the expected device ID pattern, check the mismatch between the returned and expected value for clues.

After the Get Device ID XSVF is verified to work successfully, try an XSVF file that programs the target device.

Troubleshooting

The following suggestions can be helpful in troubleshooting this design:

- If using a multiplexing scheme to switch between the processor and other JTAG control sources, check that the multiplexer is configured correctly for the JTAG control source being tested.
- Use iMPACT to execute the XSVF file(s) through a Xilinx cable to the JTAG chain.
- Generate a simple XSVF that only checks the IDCODE of the target device to test basic functionality of the hardware and software.
- Narrow the problem area by generating and executing separate XSVF files for the erase, blank check, program, and verify operations.

- Program the device from iMPACT via a download cable to verify basic hardware functionality.
 - Check for embedded memory collisions (i.e., check that there is sufficient XSVF storage memory and run-time memory to execute the XSVF without corruption).
-

Alternate Embedded Programming Solutions

The XSVF-based reference design provided in this application note is the most fully supported embedded configuration reference design for the Xilinx products. It supports all Xilinx FPGA, CPLD, and in-system programmable PROM devices. It is the only Xilinx embedded programming reference design that has full support for Xilinx XC9500/XL/XV CPLDs.

Alternate embedded programming solutions are available that can satisfy specific situations, including:

- The *Embedded JTAG ACE Player* application note [\[Ref 7\]](#) describes an HDL reference design that is suitable for implementation in an FPGA. The accompanying reference design describes how to configure FPGAs, CoolRunner-II CPLDs, or Xilinx in-system programmable PROMs through a JTAG bus using the SVF-derived ACE file (from System ACE CF).
 - For third-party flash devices without a JTAG TAP, the Spartan-3A Starter Kit includes a variety of flash programmer demonstration designs.
-

Conclusion

Xilinx CPLDs, FPGAs, and JTAG in-system programmable PROMs are easily programmed by an embedded processor. Because they are IEEE Std 1149.1 compliant, system and device test functions can also be controlled by the embedded processor. This capability opens new possibilities for upgrading designs in the field, creating user-specific features, and remote downloading of CPLD/FPGA programs.

Appendix A: C-Code Listing

The following files contain the C source code used to read an XSVF file and output the appropriate Test Access Port control bits:

C-Code Files

- `lenval.c` — This file contains routines for using the `lenVal` data structure. The `lenVal` data structure is a buffer that holds a set of bit values used in a low-level JTAG shift operation.
- `micro.c` — This file contains the main function call for reading an XSVF file from memory, interpreting the XSVF file commands, and driving the JTAG signals.
- `ports.c` — This file contains the routines to output values on the JTAG ports, to read the TDO bit, and to read a byte of XSVF data from memory.

Header Files

- `lenval.h` — This file contains a definition of the `lenVal` data structure and extern procedure declarations for manipulating objects of type `lenVal`. The `lenVal` structure is a byte oriented type used to store an arbitrary length binary value.
- `micro.h` — This file contains the declaration for the main entry point to the XSVF interpreter and definitions of possible return values.
- `ports.h` — This file contains extern declarations for providing stimulus to the JTAG ports.

To compile this C code for an embedded processor, only four functions within the `ports.c` file need to be modified:

- `setPort` — Sets a JTAG output signal (TCK, TMS, or TDI) to a specified value.
- `readTDOBit` — Reads the JTAG TDO signal value.
- `readByte` — Reads a byte of data from the XSVF file.
- `waitTime` — Consumes/waits for at least the specified amount of time and pulses the TCK signal while waiting.

Appendix B: Binary to Intel Hex Translator

This appendix contains C code that can be used to convert XSVF files to Intel Hex format for downloading to an EPROM programmer. Most embedded processor code development systems can output Intel Hex for included binary files; for those systems, the following code is not needed. However, designers can use the following C code if the development system they are using does not have Intel Hex output capability.

```
#include <stdio.h>

#define RECORD_SIZE 0x10 /* Size of a record. */
#define BUFFER_SIZE 128

/** Local Global Variables */

static char *line, buffer[BUFFER_SIZE];
static FILE *infile;

/** Extern Functions Declarations */

extern char hex( int c );
extern void puthex( int val, int digits );

/** Program Main */

main( int argc, char *argv[] )
{
    int c=1, address=0;
```

```

int sum, i;
i=0;
/**/ First argument - Binary input file ***/

if (!(infile = fopen(argv[++i], "rb"))) {
    fprintf(stderr, "Error on open of file %s\n", argv[i]);
    exit(1);
}

/**/ Read the file character by character ***/

while (c != EOF) {
    sum = 0;
    line = buffer;
    for (i=0; i<RECORD_SIZE && (c=getc(infile)) != EOF; i++) {
        *line++ = hex(c>>4);
        *line++ = hex(c);
        sum += c; /* Checksum each character. */
    }
    if (i) {
        sum += address >> 8; /* Checksum high address byte.*/
        sum += address & 0xff; /* Checksum low address byte.*/
        sum += i; /* Checksum record byte count.*/
        line = buffer; /* Now output the line! */
        putchar(':');
        puthex(i,2); /* Byte count. */
        puthex(address,4); /* Do address and increment */
        address += i; /* by bytes in record. */
        puthex(0,2); /* Record type. */
        for(i*=2;i;i--) /* Then the actual data. */
            putchar(*line++);
        puthex(0-sum,2); /* Checksum is 1 byte 2's comp.*/
        printf("\n");
    }
}
printf(":00000001FF\n"); /* End record. */
}

/**/ Return ASCII hex character for binary value. */

char
hex( int c )
{
    if((c &= 0x000f)<10)
        c += '0';
    else
        c += 'A'-10;
    return((char) c);
}

/**/ Put specified number of digits in ASCII hex. */

void
puthex( int val, int digits )
{
    if (--digits)
        puthex(val>>4,digits);
    putchar(hex(val & 0x0f));
}

```

References

1. [DS593](#), *Platform Cable USB II*
2. [XAPP503](#), *SVF and XSVF File Formats for Xilinx Devices*.
3. [XAPP104](#), *A Quick JTAG ISP Checklist*
4. <http://www.zlib.net>, *zlib compression library*
5. [XAPP067](#), *Using Serial Vector Format Files to Program XC9500/XL/XV Devices In-System*
6. [UG191](#), *Virtex-5 FPGA Configuration User Guide*
7. [XAPP424](#), *Embedded JTAG ACE Player*

Revision History

The following table shows the revision history for this document.

Date	Version	Revision
01/15/01	3.0	Revised Xilinx release.
06/25/04	3.1	Minor changes made.
03/11/05	3.2	Updated for Platform Flash PROMs.
10/01/07	4.0	<ul style="list-style-type: none"> • Updated template. • Updated document for ISE iMPACT 9.2i support. • Other minor edits and changes made.
01/13/09	4.0.1	Updated link to reference design files.
03/06/09	4.1	<ul style="list-style-type: none"> • Updated link to reference design files. • Added new Figure 2, page 3. • Updated Figure 1, page 2, Figure 3, page 4, Figure 4, page 4, Figure 5, page 5, and Figure 8, page 12. • Removed Figures 8–15 and 17. • Updated Table 1, page 7, Table 2, page 11, and Table 3, page 13. • Removed original Tables 1, 2, 3, and 5. • Updated steps in “Using iMPACT Batch Tool to Create XSVF Files,” page 5 and “Using the iMPACT GUI to Create XSVF Files,” page 8. • Removed sections: Modifications for Other Applications, XC4000 and Spartan/Spartan-XL Family Programming Algorithm, Virtex Series and Spartan-II/3/3E/3A Programming Algorithm, CoolRunner Programming Algorithm, XC18V00 PROM Programming Algorithm, memory map, port map, XC9500/XL/XV Programming Algorithm, JTAG Instruction Summary, and File Merge Utility sections. • Added sections: “Hardware Design for the JTAG Chain,” page 10, “XSVF Files for FPGA Configuration,” page 14, “Verifying and Tuning the Design Implementation,” page 16, “Special Cases for the XSVF File and XSVF Interpreter,” page 13, and “Firmware Implementation,” page 15. • Renamed 'Debugging Suggestions' section “Troubleshooting,” page 18. • Added references [Ref 3], [Ref 4], [Ref 5], [Ref 6], and [Ref 7]. • Moved Appendix-A into “Firmware Design,” page 12 section.

Notice of Disclaimer

Xilinx is disclosing this Application Note to you “AS-IS” with no warranty of any kind. This Application Note is one possible implementation of this feature, application, or standard, and is subject to change without further notice from Xilinx. You are responsible for obtaining any rights you may require in connection with your use or implementation of this Application Note. XILINX MAKES NO REPRESENTATIONS OR WARRANTIES, WHETHER EXPRESS OR IMPLIED, STATUTORY OR OTHERWISE, INCLUDING, WITHOUT LIMITATION, IMPLIED WARRANTIES OF MERCHANTABILITY, NONINFRINGEMENT, OR FITNESS FOR A PARTICULAR PURPOSE. IN NO EVENT WILL XILINX BE LIABLE FOR ANY LOSS OF DATA, LOST PROFITS, OR FOR ANY SPECIAL, INCIDENTAL, CONSEQUENTIAL, OR INDIRECT DAMAGES ARISING FROM YOUR USE OF THIS APPLICATION NOTE.